

> Zallys M6.5 con sollevamento

Trainatore elettrico progettato principalmente per la movimentazione di pesanti carichi gommati e rimorchi, facilmente collegabili grazie al sistema di sollevamento elettrico integrato. Veicolo potente e maneggevole allo stesso tempo, estremamente semplice da usare. È equipaggiato di un timone sterzante, regolabile in altezza, con sensore di sicurezza che consente l'utilizzo del mezzo solo in presenza dell'operatore. Può essere accessorizzato con vari tipi di ganci e zavorre, facilmente applicabili, che permettono di movimentare carichi su ruota fino a 7500 Kg su piano. Il motore ha un freno elettromagnetico che garantisce lo stazionamento del veicolo, che si inserisce automaticamente al rilascio dei comandi. La trasmissione con ingranaggi in bagno d'olio rende la manutenzione del veicolo quasi nulla. Grazie ai dispositivi di cui è dotato, contribuisce a rendere l'ambiente di lavoro più sicuro ed efficiente. Tutti i veicoli Zallys sono costruiti con materiale di alta qualità garantiti e certificati CE, secondo le normative europee.

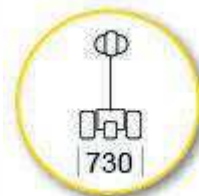

TRAINO

► Traino **elettrico con operatore a terra**

► Zallys M6.5 con sollevamento

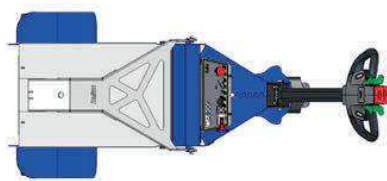
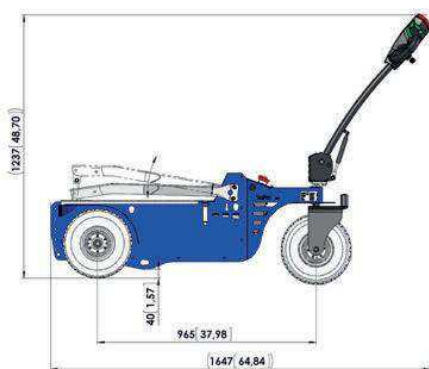
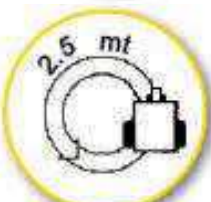

► TRAINO

www.levantelift.com